

National Concrete Masonry Association  
an information series from the national authority on concrete masonry technology

## CRACK CONTROL FOR CONCRETE BRICK AND OTHER CONCRETE MASONRY VENEERS

## TEK 10-4

Movement Control (2001)

**Keywords:** concrete brick, control joints, crack control, joint reinforcement, shrinkage, veneer

### INTRODUCTION

Concrete masonry veneer is used to provide a beautiful, economical and highly durable exterior. Concrete brick are widely used over concrete masonry, concrete frame, steel or wood structural backup. Concrete brick masonry also offers tremendous architectural versatility. The finished appearance of the wall can be altered by changing the unit size, unit or mortar color, as well as the masonry bond pattern. A wide range of surface textures is also available, such as split face, molded, striated, or "wormed," which describes a series of random, twisted indentations. In addition, concrete brick can be used to provide a traditional clay brick appearance, while offering the flexibility available with the colors and architectural finishes of conventional concrete masonry products. Tumbled concrete brick and surface color coatings are also available to simulate the look of antique brick.

The term "brick" historically refers a masonry unit that can be held in the hand, although the term is often associated with fired clay masonry. Concrete masonry veneers that resemble brick are constructed using either concrete



brick units or half-high concrete masonry units, as shown in Figure 1. Concrete brick units most commonly have a nominal thickness of 4 in. (102 mm), lengths of 8, 10, 12 or 16 in. (203, 254, 305 or 406 mm) and heights from 2 1/2 to 6 in. (64 to 152 mm). The specified size of a concrete brick is typically 3 5/8 x 2 1/4 x 7 5/8 in. (92 x 57 x 194 mm). They are usually laid with bed joints slightly larger than the standard 3/8 in. (10 mm) thickness to provide a constructed height of 2 2/3 in. (68 mm), so that three courses of concrete brick equals one 8 in. (203 mm) high module. In many cases, additional sizes and configurations are available. Consult local manufacturers for available sizes, colors and surfaces.

This TEK addresses crack control measures specifically developed for concrete masonry veneers to accommodate cracking resulting from internal volume change of the concrete masonry. Potential cracking resulting from externally applied loads is not covered. Further information on concrete masonry veneers is available in TEK 3-6A *Concrete Masonry Veneers*, TEK 16-2A *Concrete Brick Structural Design Considerations* and TEK 16-3A *Structural Backup Systems for Masonry Veneer* (refs. 3, 4 and 5).

### CONCRETE BRICK COMPARED TO CLAY BRICK

Building with concrete brick has some intrinsic differences from building with clay brick due to different material properties. One should **not** be substituted for the other without due consideration of these differences.

Concrete masonry walls have an overall tendency to shrink, whereas clay brick walls tend to expand. Both concrete and clay masonry may use movement joints to accommodate this movement, although the type of joint is different for clay than for concrete masonry. When control joints are required, concrete brick requires only vertical control joints whereas clay brick typically requires both vertical and horizontal expansion joints to accommodate panel expansion. In commercial construction, horizontal expansion joints are most often installed at each floor level below steel shelf angles used to support the clay brick. Concrete brick installations may include shelf angles as lintels over openings or in curtain wall construction.

Placing concrete brick units also differs from placing clay brick. Because the production techniques differ between concrete and clay brick, concrete brick have very consistent dimensional tolerances compared to clay brick. Concrete brick

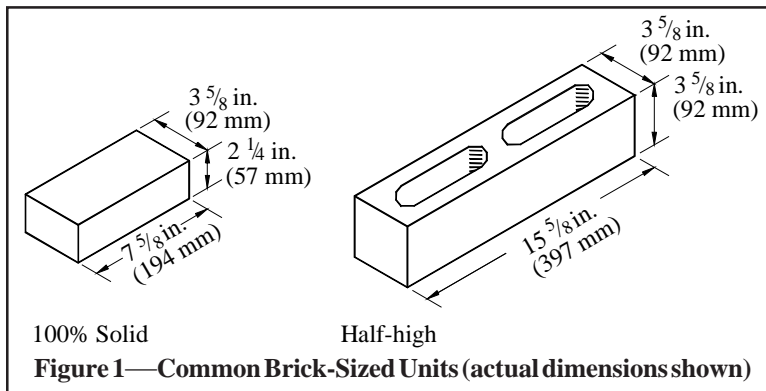

should not be wetted prior to placement. Concrete brick unit properties are summarized in TEK 1-1C, *ASTM Specifications for Concrete Masonry Units* (ref. 7).

When clay brick banding is incorporated in a concrete masonry veneer, a horizontal slip plane is used to accommodate differential movement between the two materials. See TEK 10-1A, *Crack Control in Concrete Masonry Walls* (ref. 11) for more information.

### CRACK CONTROL RECOMMENDATIONS

Concrete masonry veneer units, like all concrete products, tend to decrease in volume as drying occurs. This potential shrinkage should be provided for in the design, detailing and construction to minimize shrinkage cracking. Shrinkage cracks in concrete masonry are an aesthetic, rather than structural, concern. Because veneers, by definition, are primarily aesthetic, crack control for veneers is often a high design priority.

While movement due to moisture change is the primary focus when addressing nonstructural movement in masonry walls, temperature changes can also cause reversible shrinkage and expansion. It should be noted that darker masonry units as well as those installed on southern and western exposures will experience larger daily temperature variations due to solar exposure, and hence may require more attention to adequately address wall movement.

Crack control measures for concrete masonry veneers are similar to those for other concrete masonry walls. In fact, conventional concrete masonry crack control measures, such as those in TEK 10-2B, *Control Joints for Concrete Masonry Walls—Empirical Method* (ref. 1), have been used successfully for concrete masonry veneers in many cases.

Crack control recommendations for concrete masonry veneers are summarized below and are described more fully in the following sections.

#### Crack Control Recommendations for Concrete Masonry Veneers<sup>a</sup>

- Control joints: maximum panel length to height ratio of 1 1/2, and maximum spacing of 20 ft (6.1 m) and where stress concentrations occur
- Joint reinforcement: at 16 in. (406 mm) o.c.
- Mortar: Type N

<sup>a</sup> Adjust as needed to suit local conditions and experience.

### Unit Characteristics

Conventional concrete masonry crack control recommendations, such as those presented in TEK 10-2B, *Control Joints for Concrete Masonry Walls—Empirical Method* (ref. 1), have been developed based primarily on the performance of walls constructed using larger hollow concrete masonry units, such as the common 8 x 8 x 16 in. (203 x 203 x 406 mm).

Because the units used for veneers are often produced specifically for veneer applications, the physical properties may differ from those of larger concrete masonry units. These differences can impact how the concrete masonry veneer moves and reacts to changes in moisture content and temperature. Hence, crack control recommendations have been tailored specifically for concrete masonry veneers.

Ensuring that the concrete masonry units are relatively dry when laid and remain dry during construction will also help minimize initial drying shrinkage of the wall.

Techniques to minimize water absorption by the veneer will also help limit subsequent movement due to moisture loss. Some manufacturers have had success in reducing veneer movement by incorporating integral water repellents in the veneer units during manufacture. When used in the units and added to the mortar on site, integral water repellents help minimize water absorption. See TEK 19-1 *Water Repellents for Concrete Masonry Walls* (ref. 2) for additional information on integral water repellents.

### Mortar

Using a lower compressive strength mortar helps ensure that when cracks do occur, they occur in the mortar joint rather than through the unit. Type N mortar is often specified for concrete brick veneers, because it tends to be more flexible than other mortar Types. ASTM C 270, *Standard Specification for Mortar for Unit Masonry* (ref. 6) recommends Type O mortar for exterior above grade nonloadbearing walls where the masonry is unlikely to be frozen when saturated, or unlikely to be subjected to high winds or other significant lateral loads. C 270 recommends that Type N or S mortar be used in other cases.

### Joint Reinforcement

Horizontal joint reinforcement effectively limits crack width by holding any cracks that form tightly together. For this reason, joint reinforcement, spaced at 16 in. (406 mm) on center, is recommended in concrete masonry veneers, although acceptable performance has been achieved without joint reinforcement in some cases.

To protect joint reinforcement from corrosion, *Specification for Masonry Structures* (ref. 9), requires at least 5/8 in. (16 mm) of mortar cover between the joint reinforcement and the weather-exposed face of the masonry.

When both joint reinforcement and control joints are used, the joint reinforcement should be discontinued at the control joint to avoid restricting horizontal movement at the joint.

### Control Joints

Control joints are vertical separations built into the veneer

and located where stress concentrations are likely to cause cracks. The joints allow unrestrained longitudinal movement, thereby relieving horizontal tensile stress that may develop due to shrinkage.

Ideally, a control joint should be located wherever masonry volume changes are likely to cause cracking. Because this can be difficult to determine in practice, the following are general guidelines for locating control joints.

For veneer panels without openings or other points of stress concentration, control joints are used to effectively divide a wall into a series of panels. In general, it is desirable to keep these panels as square as possible to minimize cracking between the control joints. When this is not possible, the panel length to height ratio should be limited to 1 1/2, with a maximum control joint spacing of 20 ft (6.1 m). Control joint spacing should be adjusted where local experience justifies.

Whenever possible, control joints should be located where stress concentrations occur, such as: at changes in wall height or thickness; at inside corners; within 4 in. (102 mm) of outside corners; and near one or both sides of large door and window openings. Note that every opening does not necessarily require control joint(s), particularly in buildings with many small openings (see *Residential Construction* section, below). Note that control joints should line up with the end of the lintel, rather than be placed through the lintel, as shown in Figure 2.

Veneers are typically attached to a structural backup with adjustable ties or anchors (for tie and anchor types, design

criteria and spacing requirements, see TEK 12-1A, *Anchors and Ties for Masonry* (ref. 8)). Ties should be placed within 12 in. (305 mm) of the control joint. When flexible ties are used, control joint locations need not align with control joints in the backup when a masonry backup wythe is used, although it is considered good practice to align them. If the veneer is rigidly bonded to a masonry backup, however, control joints should extend through the backup and veneer in the same location.

### Residential Construction

Control joint recommendations for larger buildings typically call for a control joint at each window, and on both sides of the window if the window is over 6 ft (1.8 m) wide (ref. 1). However, this may be difficult to accomplish in residential construction because of the large number of relatively small openings. One strategy is to use control joints to divide the wall into panels that are no longer than they are high. Because residential buildings typically have fewer stories than commercial, this often results in closer control joint spacings than are common in commercial buildings.

Figure 2 shows a residential facade with recommended control joint locations. As an alternative to the right-hand joint shown in Figure 2, a control joint could be placed through or to one side of the garage door. Horizontal joint reinforcement placed at 16 in. (406 mm) o.c. will help compensate for not placing control joints at every window opening.

In residential construction, veneers are most often supported by wood frame construction (see Figure 3). Detailed requirements for masonry veneer over wood frame are described in TEK 3-6A, *Concrete Masonry Veneers* (ref. 3).

### CONTROL JOINT CONSTRUCTION

Structural masonry walls require that control joints permit free longitudinal movement while resisting lateral or out-of-plane shear loads. Because veneers are nonstructural, veneer control joints need only permit unrestricted longitudinal movement. This can be accomplished by raking out the mortar joint and installing a backer rod and appropriate sealant, as shown in Figure 4. The backer rod and sealant allows in-plane movement while keeping the joint weathertight.

Several strategies are used to make control joints less noticeable. Perhaps the simplest approach is to locate the vertical control joint behind a downspout. If the architectural style allows it, a recess can be built into the veneer to create a vertical shadow line and provide an inconspicuous control joint location, or the control joint can be aligned with another architectural feature. When quoins are used, the control joint can be placed adjacent to the edge of the quoin to make it less noticeable. Although more difficult to construct than the other options, another alternative is to stagger the control joint to follow the mortar joint, as illustrated in Figure 5. In this case, the horizontal legs of the joint need to allow longitudinal movement. This can be accomplished by placing building paper or another bond break material in the mortar joint. This detail is best for one and two-story construction, where the weight of the veneer will not cause enough friction to restrain movement.



Figure 2—Example of Residential Control Joint Placement

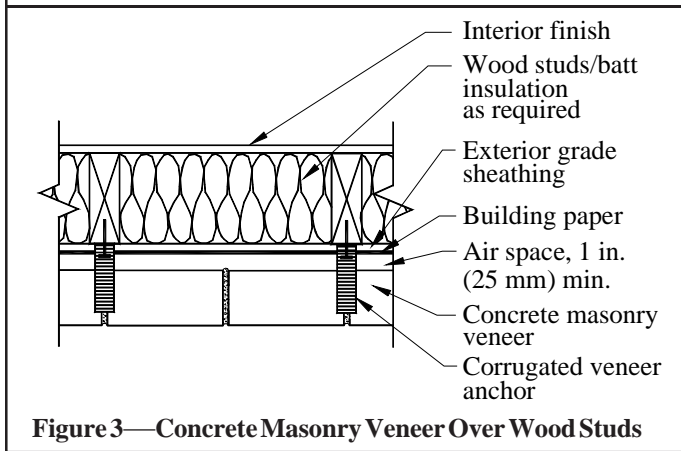

Figure 3—Concrete Masonry Veneer Over Wood Studs

**REFERENCES**

1. *Control Joints for Concrete Masonry Walls—Empirical Method*, TEK 10-2B. National Concrete Masonry Association, 2001.
2. *Water Repellents for Concrete Masonry Walls*, TEK 19-1. National Concrete Masonry Association, 1995.
3. *Concrete Masonry Veneers*, TEK 3-6A. National Concrete Masonry Association, 1995.
4. *Concrete Brick Structural Design Considerations*, TEK 16-2A. National Concrete Masonry Association, 1998.
5. *Structural Backup Systems for Masonry Veneer*, TEK 16-3A. National Concrete Masonry Association, 1995.
6. *Standard Specification for Mortar for Unit Masonry*, ASTM C 270-00. American Society for Testing and Materials, 2000.
7. *ASTM Specifications for Concrete Masonry Units*, TEK 1-1C. National Concrete Masonry Association, 2000.
8. *Anchors and Ties for Masonry*, TEK 12-1A. National Concrete Masonry Association, 2001.
9. *Specification for Masonry Structures*, ACI 530.1-99/ASCE 6-99/TMS 602-99. Reported by the Masonry Standards Joint Committee, 1999.
10. *Crack Control in Concrete Masonry Walls*, TEK 10-1A. National Concrete Masonry Association, 2001.

